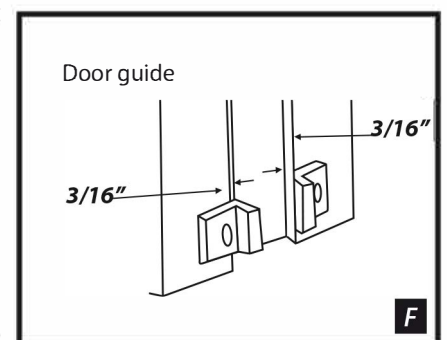
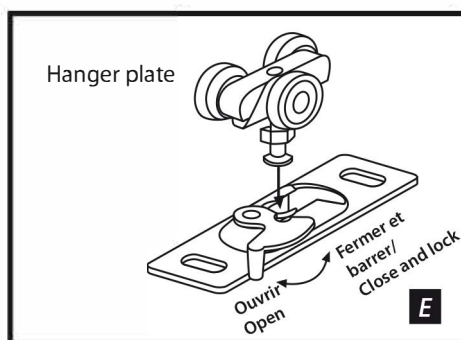
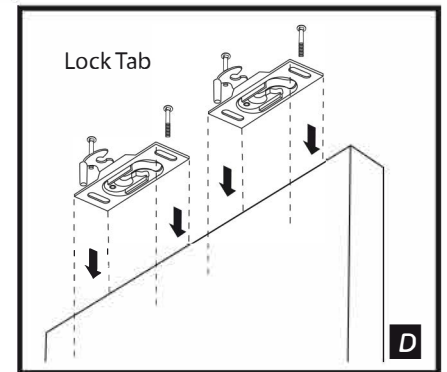
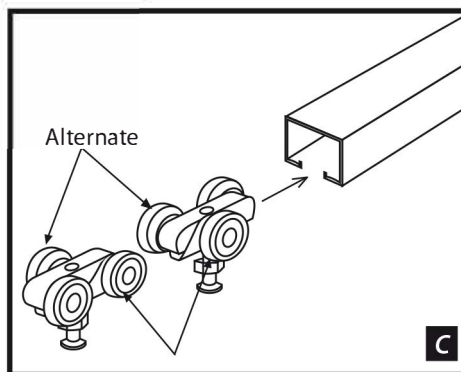
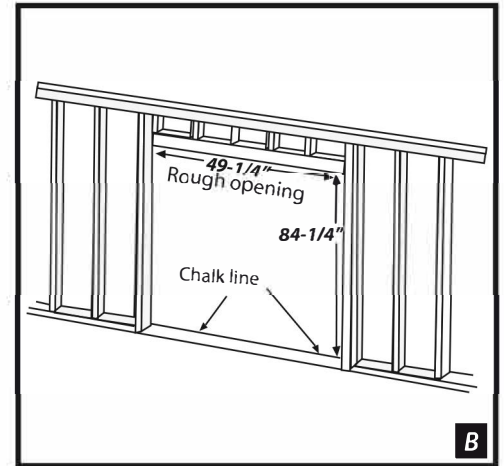
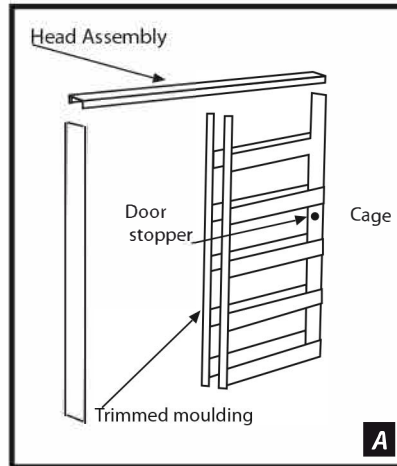

The instructions are based on standard door sizes, 24", 30", 32" ou 36" X 80" height.

The rough opening should be equal to the height of the door (80") + 4 - 1/4" = 84 - 1/4" et 2 X door width + 1 - 1/4".

Example: 24" X 2=48" + 1 - 1/4" = 49 - 1/4" (see diagram B).

- 1 Remove the trimming mouldings which are temporarily attached at the top to the pre-assembled pocket door head assembly, *diagram A*.
- 2 Using a chalk line, trace a line from one end of the opening to the other on each side, *diagram B*.
- 3 Insert the header assembly on top of the cage of the pocket door, *diagram A*.
- 4 Insert the complete pocket door into the opening using the chalk lines as your guide.
- 5 Screw the header assembly to the top part of the opening using the provided 2-3/4" screws. Shim the header assembly with shingles making sure that it is level.
Note: the door will not remain in place if the track is not level.
- 6 Nail the frame cage to the side of the opening and on the floor of the pocket door, again making sure it is level.
- 7 Insert the two rollers into the track, making sure that the 2 rollers are opposite to each other on the track, *diagram C*.
- 8 Screw the door stopper at the centre of the board of the cage, *diagram A*.
- 9 Install the hanger plates at the top of the door at 2" from the edge on each side of the door, *diagram D*.
- 10 Install the door by placing the hanger plates under the adjustable roller screws and by pushing them in the lock tab, *diagram E*.
- 11 Install the door guides at the bottom of the opening of the frame so that the door is in the centre of the opening, *diagram F*.
- 12 Install the trimmed mouldings on the header assembly and on the side of the opening, *diagram A*.

**CONVERSION**

2" = 5.1 cm	3/16" = 4.7 mm	24" = 60.9 cm	32" = 81.2 cm	48" = 121.9 cm	84-1/4" = 214 cm
4-1/4" = 10.7 cm	30" = 76.2 mm	36" = 91.44 cm	49-1/4" = 125.9 cm	80-1/4" = 203.8 cm	